

Event: 1 Social Car10 2011
 Date: 2011-03-06
 Track: Car10
 City: Barakaldo Spain
 Name: Miguel Angel Perez Diez



Ver. 0701E



Track conditions
 Size: Open Med. Tight
 Traction: High Med. Low
 Surface: Smooth Med. Bumpy

Front suspension

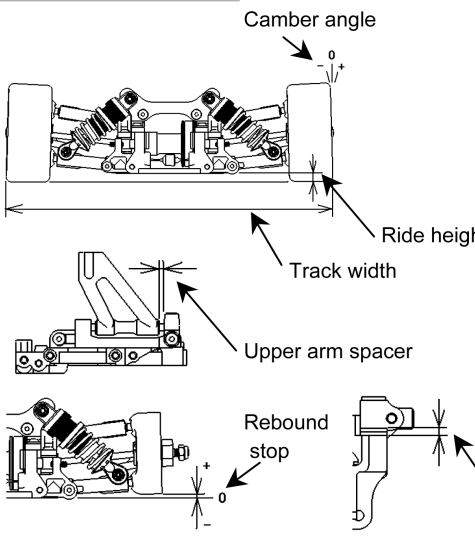

Track width 199 mm
 Ride height 6 mm
 Camber angle -2 °
 Upper arm spacer 2 mm
 Toe angle out 1 °
 Rebound stop 0 mm
 Bump stop None Use
 Upper arm position 1 mm
 Anti-roll bar 45
 Upright T0138-B T0164
 Upper arm position 1 mm

Front shock

Piston Stock
 Oil # 600
 Spring Light blue
 Sock position

Front Diff.

One way
 Gear diff. Oil # 100000
 Solid

Steering ackerman

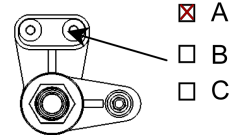

Rear suspension

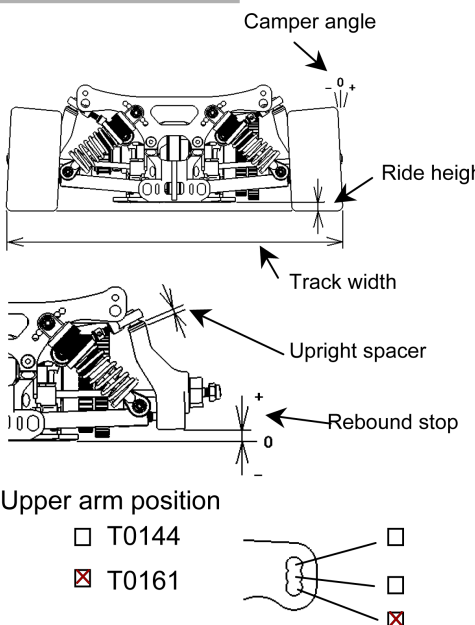

Track width 200 mm
 Ride height 7 mm
 Camber angle -3.5 °
 Toe angle in 2.5 °
 Rebound stop 4 mm
 Bump stop None Use
 Lower arm position
 Upright spacer 2 mm
 Anti-roll bar Wire Adjustable(T0162)
 Upper arm position 0 mm
 Wheel Hub Spacer 0 mm

Rear Shock

Piston Stock
 Oil # 600
 Spring Light blue
 Shock position

Rear Diff.

Oil # 30000

Engine Type Nova 353-08
 Gasket 0.3 mm Muffler Nova EFRA 2630
 Plug 5 Fuel Runner Time TOP16

Tire <Front> Type 35 Enneti <Rear> Type 35 Enneti
 Dia.(start) L 60 /R 60 Dia.(start) L62.5/R 62.5
 Dia.(finish) L57.7 /R 56.7 Dia.(finish) L60.5/R 58.9

Clutch

Clutch shoe Black Gray Yellow
 Centrifugal shoe Lightweight x 2
 Spring Hard
 Clutch bell clearance 0.4 mm
 Spring adj. Nut position 0.8 mm

Brake pad

Black Other

Body Type ALTIS 2.3 2027
 Wing _____

Drive ratio

Gear ratio Side pulley
 1st. 17 / 60 24T
 2nd. 22 / 53 25T

Result
 Race time / Lap 30:06.935 / 95 Puesto 1
 Best lap (1Lap) 17.590

Comments:
 Medio grado mas de caída a las ruedas derechas. Pista con agarre medio. Vuelta rapida de carrera en 16:370 de Jorge Vegas y rodaba en 16 altos. Muy buen comportamiento del coche. Chasis 4mm.