

Event: Latvian Championship RD6
 Date: 2008-07-26
 Track: RBSSKALS
 City: Riga Latvia
 Name: Mindaugas Ambrasas



Ver. 0701E



Track conditions
 Size: Open Med. Tight
 Traction: High Med. Low
 Surface: Smooth Med. Bumpy

Front suspension

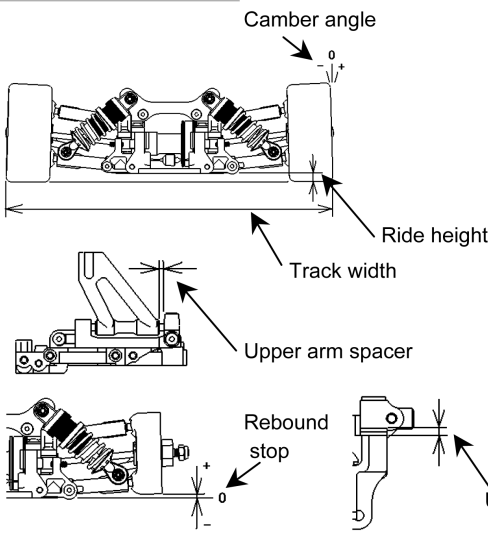

Track width 200 mm
 Ride height 6.5 mm
 Camber angle 2.5 °
 Upper arm spacer 2 mm
 Toe angle 1 °
 Rebound stop -2 mm
 Bump stop None Use
 Upper arm position 0 mm
 Anti-roll bar flat
 Upright T0138-B T0164
 Upper arm position _____ mm

Front shock

Piston stock
 Oil # 350
 Spring TM aqua
 Sock position

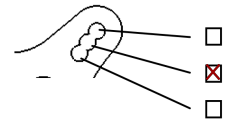

Front Diff.

One way
 Gear diff. Oil # _____
 Solid

Steering ackerman

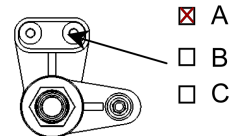

Rear suspension

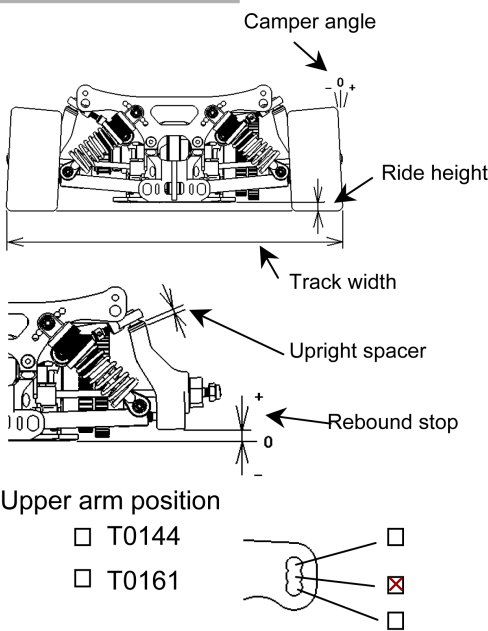

Track width 200 mm
 Ride height 7.5 mm
 Camber angle 3.5 °
 Toe angle 3 °
 Rebound stop 0 mm
 Bump stop None Use
 Lower arm position
 Upright spacer 2 mm
 Anti-roll bar Wire Adjustable(T0162) ϕ 2.1
0 mm
 Wheel Hub Spacer 0 mm
 Upright spacer T0144 T0161
 Rebound stop

Rear Shock

Piston stock
 Oil # 350
 Spring TM Blue
 Shock position

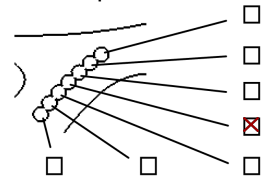

Rear Diff.

Oil # 10000

Engine Type LRP Spec4.
 Gasket _____ mm Muffler EFRA 2644
 Plug R7 Fuel Power Save

Tire <Front> Type Twister 37 <Rear> Type Twister 40
 Dia.(start) L 61 /R 61 Dia.(start) L 63 /R 63
 Dia.(finish) L /R Dia.(finish) L /R

Clutch

Clutch shoe Black Gray Yellow
 Centrifugal shoe _____
 Spring _____
 Clutch bell clearance 0.5 mm
 Spring adj. Nut position 0.4 mm

Brake pad

Black Other

Body

Type PF Stratus 3.1
 Wing STD

Drive ratio

Gear ratio Side pulley
 1st. 17 / 53 24T
 2nd. 23 / 59 25T

Result

Race time / Lap 90 total
 Best lap (1Lap) 15.200

Comments:

Withdrew because of radio problems. Car was better than ever, lacking only fractions of corner speed and suffering gearbox problems. Was possible to go for ~110-111 laps.